

# Wind Speed & Direction Sensor

## Key Features

- **Wind Speed & Direction Sensor**
- **0-60m/s (116 knots) Wind Speed**
- **0-360° Wind Direction**
- **NMEA output**
- **Low Power consumption**
- **Fast start-up**
- **Solid-state – maintenance-free**
- **Corrosion Free**

The Gill WindSonic is a low-cost anemometer, which utilises Gill's proven ultrasonic technology to provide wind speed and direction data via one serial or two analogue outputs. To confirm correct operation, outputs are transmitted together with an instrument status code.

With a robust, corrosion-free polycarbonate housing, this small, lightweight wind sensor is recommended for use in harsh environmental conditions and is particularly suited to marine & offshore (ships, data buoys) and land based installations. The WindSonic has no moving parts, offering maintenance-free operation in a wide range of applications.



### WIND SPEED

Range	0 - 60 m/s (116 knots)
Accuracy	±2% @12 m/s
Resolution	0.01 m/s (0.02 knots)
Response Time	0.25 seconds
Threshold	0.01 m/s

### DIRECTION

Range	0 - 360° (No dead band)
Accuracy	±2° @12 m/s
Resolution	1°
Response Time	0.25 seconds

### MEASUREMENT

Ultrasonic Output Rate	0.25, 0.5, 1, 2 or 4 Hz
Parameters	Wind Speed & Direction or U and V (vectors)
Units of Measure	m/s, knots, mph, kph, ft/min

### OUTPUTS

Option 1	RS232
Option 2	RS232 + RS422 + RS485*** + NMEA*
Option 3	RS232 + RS422 + RS485*** + NMEA* 0-5V or, 0-20mA or 4-20mA
Option 4	SDI-12 (refer to manual or separate data-sheet for technical specification)
Baud Rate	2400 to 38400
Anemometer Status	Supplied as part of standard message

### POWER REQUIREMENT

Anemometer	5-30VDC Option 1 & 2
	7-30VDC Option 3
	9-30VDC Option 4
Current Drain	Dependent on option selected e.g. < 2mA @ 12V (SDI-12) to 44mA @ 12V (4-20mA) Refer to manual for further advice
	Start up time < 5 seconds

### MECHANICAL

External Construction	LURAN S KR 2861/1C ASA/PC
Size	142mm x 163mm
Weight	0.5kg

### ENVIRONMENTAL

Protection Class	IP66
Operating Temperature	-35°C to +70°C
Storage Temperature	-40°C to +80°C
Operating Humidity	< 5% to 100% RH
Precipitation	300mm/hr
EMC	EN 61326: 1998

### OPERATIONAL

MTBF	15 years
Warranty	2 years
Factory Calibration	Traceable to National Standards

### ACCESSORIES

Wind Software	Display / Logging**
Pipe Mounting (optional)	44.45mm (1.75 in) diameter
Cables (optional)	Available to match output options
Display (optional)	See Gill Display datasheet

\* NMEA 0183

\*\* Download software free from [www.gillinstruments.com](http://www.gillinstruments.com)

\*\*\* 2-wire is point to point only

## Typical Applications

- Remote weather monitoring stations
- Building controls
- Data buoys
- Marine vessels
- Small airports & helipads
- Road & rail tunnels
- Environmental field sites
- Ports & harbours
- Mobile weather monitoring vehicles
- Coastal weather monitoring stations

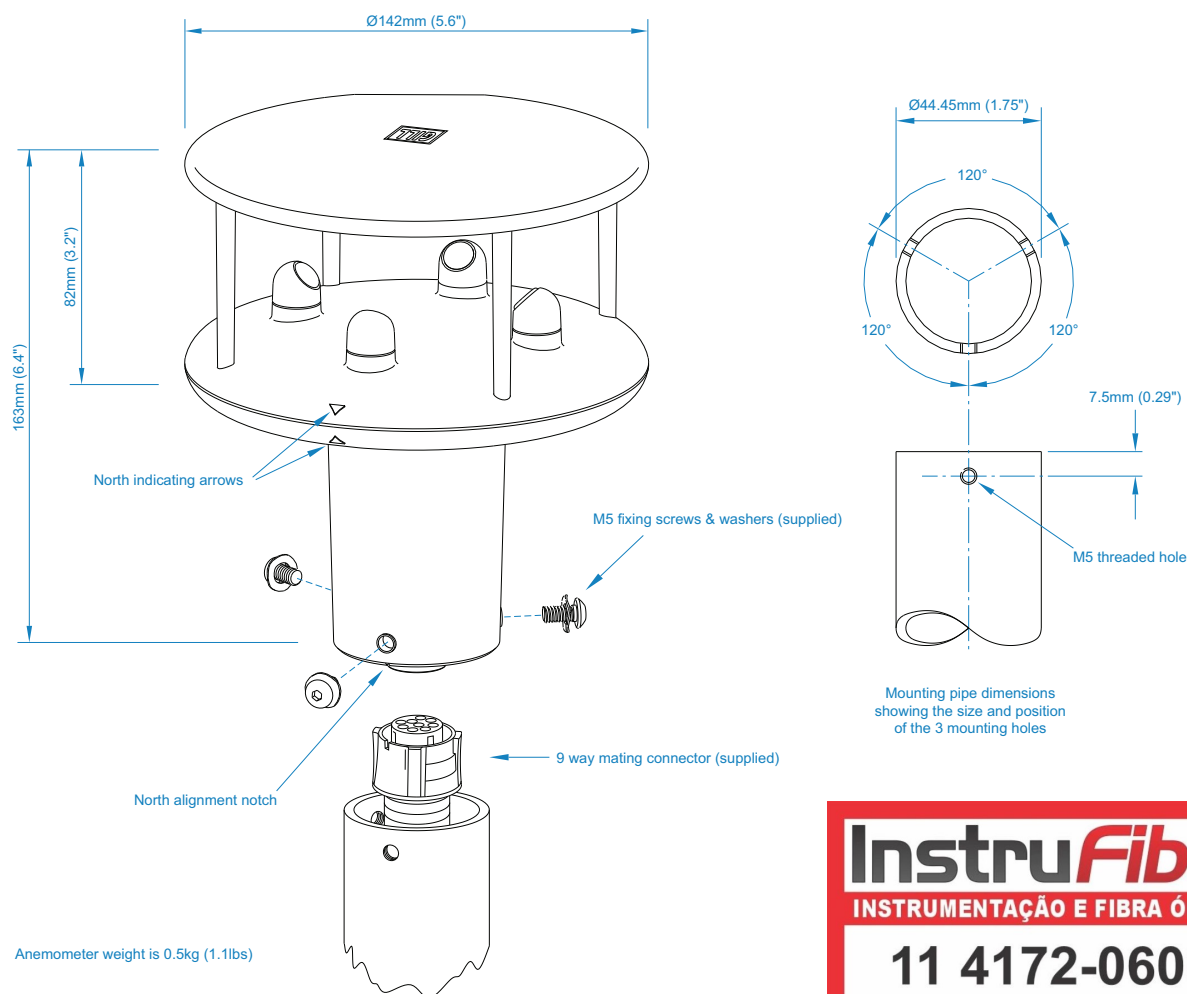

**InstruFiber**  
 INSTRUMENTAÇÃO E FIBRA ÓPTICA

**11 4172-0606**  
**11 4386-0362**

Specifications may be subject to change without prior notice.

# GILL

### Gill Instruments Limited

Saltmarsh Park, 67 Gosport Street  
 Lymington, Hampshire  
 SO41 9EG United Kingdom

Tel: +44 (0) 1590 613 500

contact@gillinstruments.com

# AUPAME

[www.aupame.com.br](http://www.aupame.com.br)  
[vendas@aupame.com.br](mailto:vendas@aupame.com.br)

[gillinstruments.com](http://gillinstruments.com)

1405-027 Iss 8

Copyright © Gill Instruments 2022

Gill Instruments Ltd, Reg No. 2281574

Registered Office: Towngate House, 2-8 Parkstone Road, Poole. BH15 2PW